

A NEW APPROACH TO COUPLING/DECOUPLING NETWORKS FOR EMC TESTING

R C Marshall

Richard Marshall Limited, UK

ABSTRACT

Testing of immunity to EN61000-4-6 and of emission to EN55022 is achieved using Coupling and Decoupling networks (CDNs).

The paper will describe several improvements to the configuration, construction and connection of such networks.

Firstly it will be shown that embodying the whole of the 150Ω source impedance within the CDN, together with built-in voltage measurement, substantially reduces the energising power required and so reduces system cost. At the same time this simplifies calibration.

Secondly the factors limiting frequency response will be analysed, and it will be shown that with a carefully-designed CDN and a sufficiently small EUT it is certainly practicable to extend the maximum injection frequency to 400MHz.

Lastly it will be described how a limited set of CDNs can be adapted to meet a large variety of practical applications in telecommunications, computing, and process control by appropriate CDN internal design and linking within the CDN connectors.

The improved versatility and wider frequency range are equally applicable to emission testing to EN55022.

BACKGROUND

EN61000-4-6 describes test requirements for conducted immunity to intended rf transmitters in the range from 150KHz to 80MHz. For small equipment its application may be extended up to 230MHz provided that the largest dimension of the Equipment Under Test (EUT) does not then exceed $\lambda/4$. Central to the application of this standard is the use of a Coupler/Decoupler Network (CDN) on every cable that is connected to the Equipment under Test (EUT). These CDNs establish a 150Ω common-mode impedance for each cable, and allow the introduction of the required immunity test signal onto just one cable. It is of course necessary that these networks be appropriate to the conductor make-up and circuit function of each EUT cable as well as setting the correct EMC test parameters, so basic requirements and a number of examples are given in the standard. The network has to be close to the EUT to obtain reproducible results.

EN55022 makes use of similar CDNs for emission testing. It also introduces a CDN configured as a transformer (in figure D3) and the concept of controlled longitudinal conversion loss (in para. 9.5) when testing wide-band telecommunication cables.

The CDN configuration is most easily understood in the case of the coupling network for a shielded cable as shown in figure 1. Here a voltage source is applied to the shield via a 150Ω resistor, and shunt effects due to the ongoing cable to associated equipment are minimised by the common-mode isolating inductor, which in practice has a ferrite core. The shield is bonded to the ground plane on the side that connects to the Associated Equipment (AE) so as to minimise any environmental coupling of that cable. Figure 2 shows the equivalent network for an unshielded cable. Since there is no shield coupling is onto the functional circuit - in this case a 4-core data cable -and each of the four resistors must be four times the desired 150Ω, that is 600Ω. Blocking capacitors may be used, but above the cut-off frequency each pair is bridged by 1,200Ω, which may be low enough to affect the operation of some circuits. Since there is no shield to ground on the AE side small decoupling capacitors are provided there - but these also must be compatible with functional

circuit requirements. EN61000-4-6 includes an example CDN where centre-tapped inductors are added to minimise the loading effect of these coupling and decoupling components.

IMPEDANCE PARTITIONING

The example CDNs in EN61000-4-6 actually implement the 150Ω common-mode source impedance as a 100Ω local element plus 50Ω generator source impedance, as shown here in figure 3. The standard has made a curious choice because this approach guarantees a gross mismatch between the injection power source and the CDN. This would give serious gain fluctuations with frequency and cable length if the standard did not also recommend the insertion of a 6dB attenuator. However this attenuator puts up the power requirement fourfold - and a wide-band power amplifier is an expensive item, and a wide-band power attenuator is not cheap. Note that the amplifier, attenuator, and rf connecting cables are all part of the calibrated configuration. It really does seem better to return to the fundamental arrangement of figure 1 where all the required injection impedance is provided locally in the CDN to reduce the required power amplifier rating and minimise the number of items involved in the calibration process. Furthermore it is beneficial to have all the injection impedance local to the CDN so as to maximise the resistance that may bridge functional circuits as shown in figure 2.

This and other improvements have been incorporated into a new family of CDNs which still retain conformance to EN61000-4-6. This family design is described below. Further information will be found in the product literature (3).

THE VERSATILE CDN

Impedance partitioning

To implement the required injection impedance locally in the CDN as proposed above and so obtain the desired power-saving and simplicity of calibration requires the inclusion of an rf voltage monitor at the CDN terminals. We have chosen to embody a diode rectifier giving a dc output that may be monitored with a standard voltmeter, or by an oscilloscope when immunity to modulated signals is under investigation. This signal may also be used as feedback to a power levelling arrangement if desired.

EN61000-4-6 states in Annexe E that a 7 watt test generator is required to conduct 80% amplitude-modulated testing to industrial limits with the exemplary CDNs, but the associated attenuator actually increases this to at least 15 watts at the amplifier terminals. Using the VCDN the required amplifier power rating is certainly less than 7 watts. In practice, due to the benefit of the load mismatch, a 5 watt amplifier has proved adequate.

Frequency response

The EN61000-4-6 requirement of $<\lambda/4$ at 230MHz equates to a longest equipment dimension of 326mm. Many electronic products are smaller than this, so it is useful to consider if CDNs could be implemented for higher frequencies. It has been determined that reducing the end-to-end capacitance of the common-mode isolating toroid by using the so-called Super Toroid winding arrangement proposed by Gross (4) and shown in figure 4, together with a more compact layout within a non-conducting enclosure will give another octave of useful response, as may be seen in figure 5. Consequently there is scope for informal testing up to 460MHz now, and potential for new product standards to extend the method of EN61000-4-6 accordingly.

Versatility

Most users will want to test many different kinds of EUT, most of which will be unknown at the time of equipment purchase. To discover that a suitable CDN is not available on the day that testing is to start can be embarrassing. For this reason and to minimise capital investment, each CDN should be usable in as

many different situations as possible. To make a CDN versatile in this sense requires that it be engineered so that a single unit may be used on a variety of cable types and circuit functions.

As a simple example a CDN for a 4-core shielded cable may also be used on 1, 2, or 3 core EUT cables if suitable adapters can be provided. There may even be a choice of differential-mode characteristic impedance since a single-core coaxial EUT cable can be made up with 1, 2, 3, or 4 cores forming the "inner" and the remainder paralleled with the shield to form the "outer". Of course, there may be a few really-critical applications where reflection at the adapter may be a problem, but this may usually be cured by deliberately adding some attenuation in the signal path. This principle can be extended to cover both unshielded and shielded applications with a single CDN by bringing out to the adapter a multiple of injection resistors that may be connected to each individual core of an unscreened EUT cable, or paralleled onto the overall shield if this is available. This arrangement is illustrated in figure 6. It will be evident that the 4 cores may also be paralleled for use as a single pair, with two injection resistors to each composite conductor.

Careful layout of the adapter connectors is necessary to optimise cable balance and injection in all configurations, but the result is a useful improvement in versatility. For example, a VCDN with a maximum capability of 6 cores and overall shield may be used for shielded or unshielded cables of 1 to 6 cores, including circuit functions such as one or three pair telecommunications or audio cables and two or three core power cables. An 8-core VCDN, basically designed for four-pair Cat.5 data cables, can equally serve for one or two pair telecommunications, and for process control or digital circuits of 1 to 8 cores, shielded or unshielded. The same principles have been implemented for data cables of up to 25 cores, whilst still maintaining an ability to directly mate the AE and EUT adapter connectors without the VCDN in circuit, which is useful for set-up work.

CONCLUSION

EN61000-4-6 and EN55022 provide accessible and reproducible methods of cable-based EMC testing without need of calibrated test chambers.

The improved CDNs presented above can provide easier application of these methods at substantially reduced overall system cost.

ACKNOWLEDGEMENT

Some of the arrangements described in this paper are the subject of patent applications.

REFERENCES

1. 1996, "Electromagnetic Compatibility (EMC) Part 4: Testing and measurement techniques Section 6: Immunity to conducted disturbances induced by radio-frequency fields" European Standard EN61000-4-6:1996.
2. 1997, "Information Technology Equipment - Radio disturbance characteristics - limits and methods of measurement", IEC CISRP22:1997.
3. 1999, "Product Specification, Series 0046 Versatile Coupling/Decoupling Networks", Richard Marshall Limited, 30 Ox Lane, Harpenden, AL5 4HE, UK
- 4.. Gross, T A O, 1976, "Super Toroids with zero external field made from regressive windings", Electronic Design, September 1st.

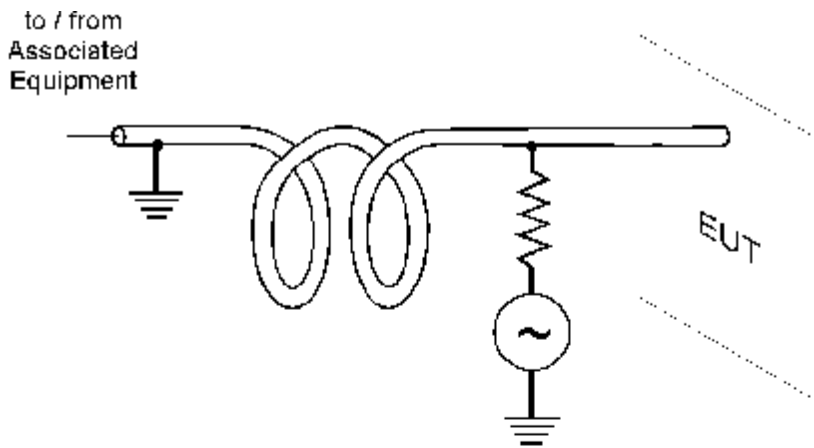

Figure 1. Basic Coupling Network for a shielded cable

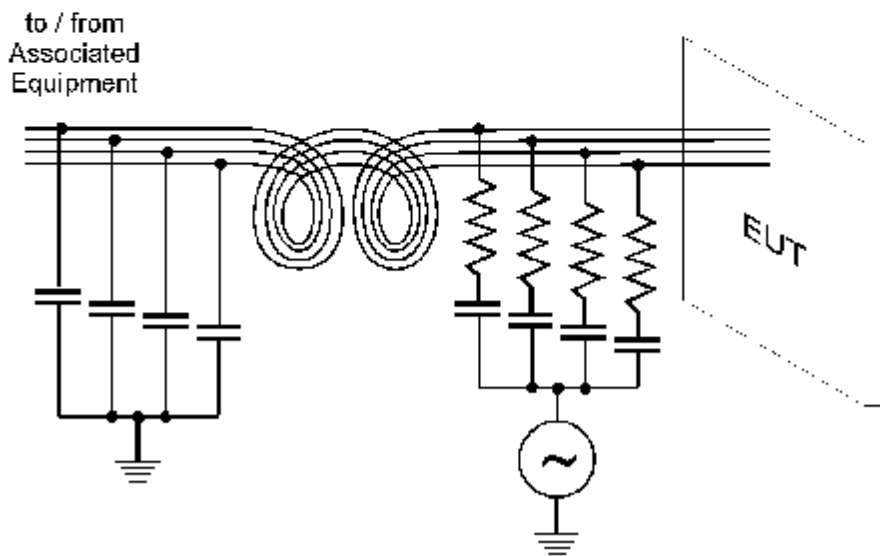

Figure 2. Basic Coupling Network for a 4-core unshielded cable

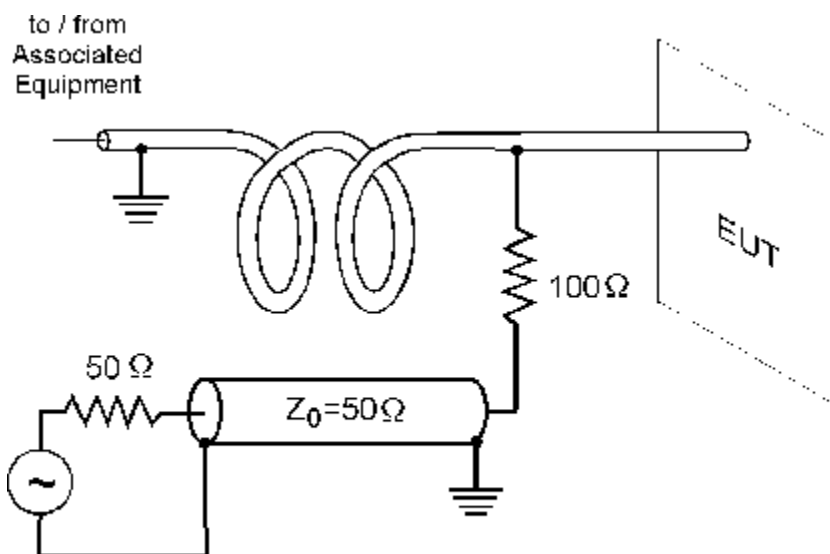

Figure 3. Partitioning of common-mode source impedance



Figure 4. The supertoroid

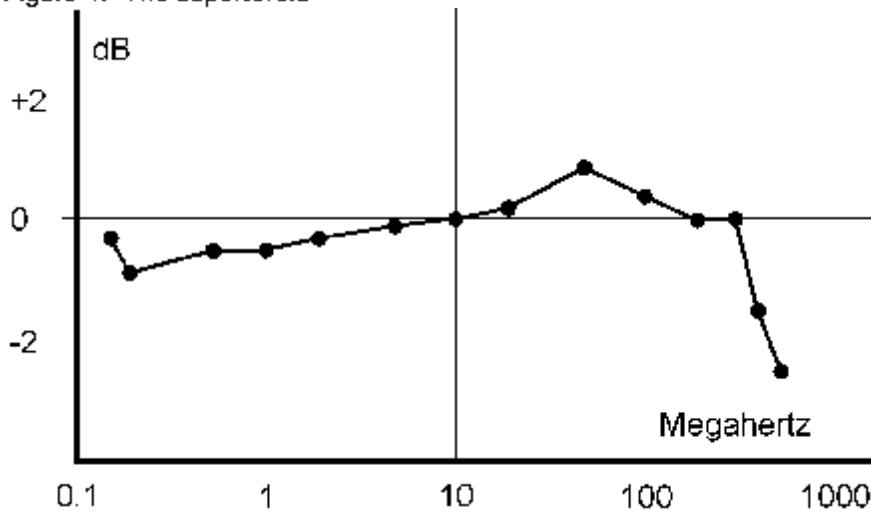

Figure 5. Frequency response of Versatile CDN

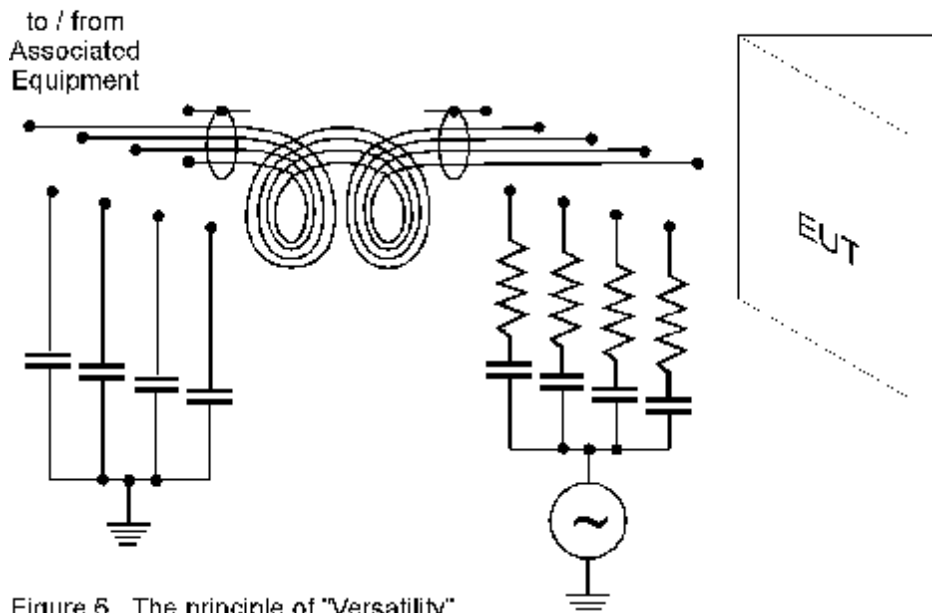

Figure 5. The principle of "Versatility"